







THIS DRAWING IS UNPUBLISHED. RELEASED FOR PUBLICATION, 19 .
 © COPYRIGHT 19 BY AMP INCORPORATED. ALL RIGHTS RESERVED.

LOC	DIST	REVISIONS			
P	LTR	DESCRIPTION	DATE	DWN	APVD
AG	53	D	REDWN ON CAD PER 0650-0207-98	24-JUN-99	LM GR

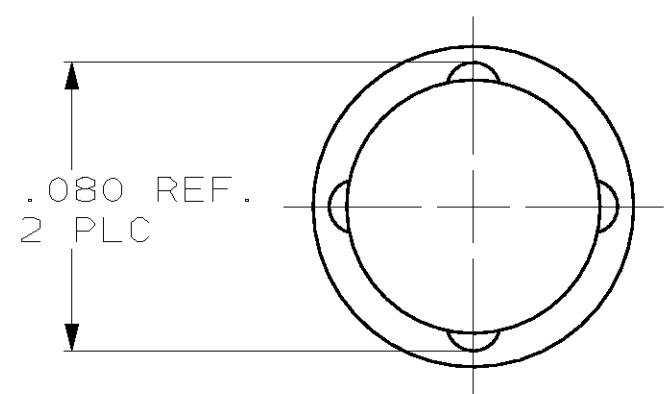
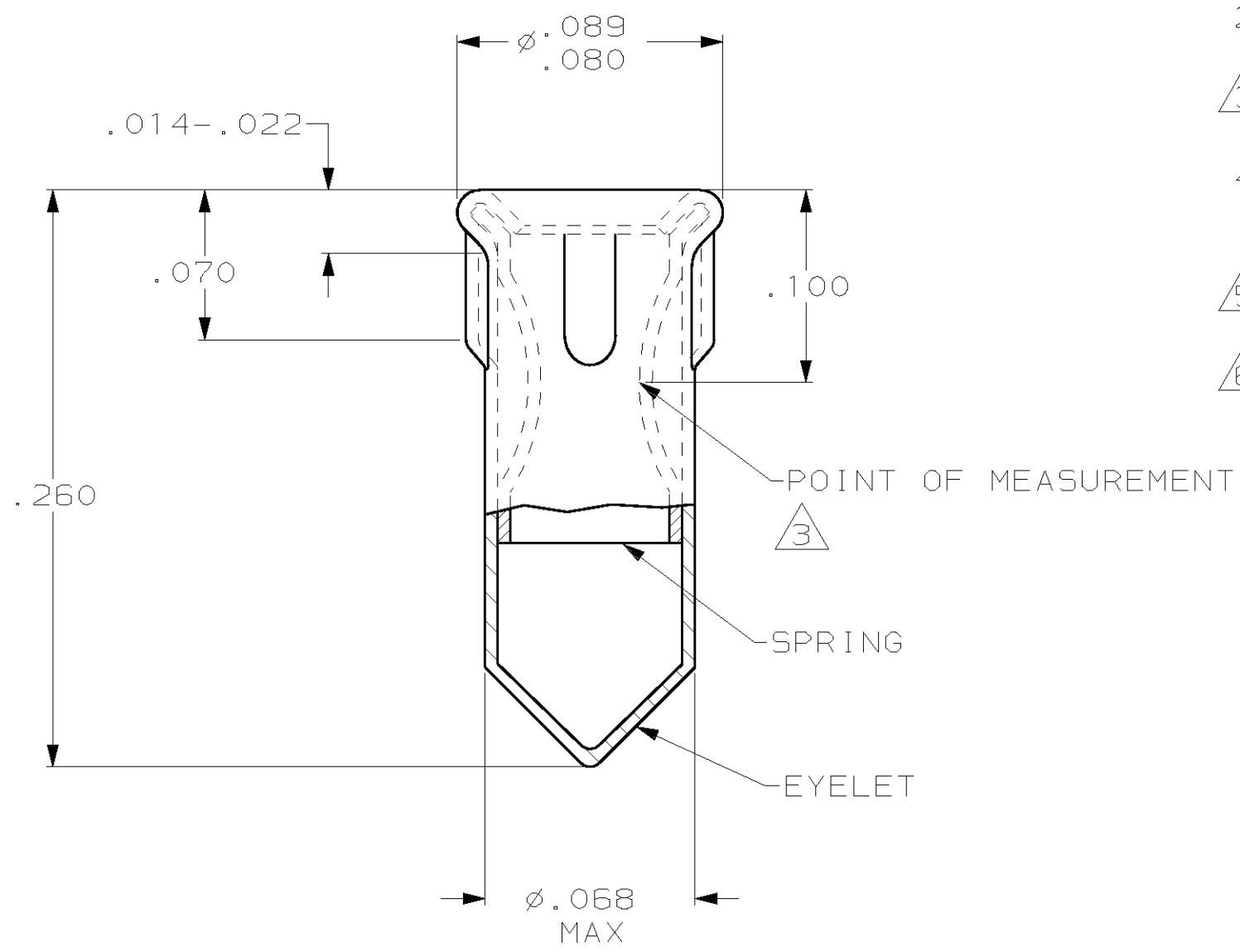
- MATERIAL: EYELET-COPPER (QQ-C-533)
SPRING-BERYLLIUM COPPER (QQ-C-576).
- TIN PL. .000150 MIN THK
-  GOLD PL. .000030 MIN THK
- RECOMMENDED HOLE SIZE FOR MACHINE INSERTION .069-.075
-  TIN PLATE .000100 MIN THK
-  TIN-LEAD PLATE .000150 MIN THK



DIA	LENGTH	SPRING	EYELET	PART NUMBER
.037-.041	.100-.210			645500-3
.037-.041	↑	NOTE 5	↑	645500-2
.037-.041	.100-.210	NOTE 3	NOTE 2	645500-1

THIS DRAWING IS A CONTROLLED DOCUMENT.		DWN L.A. McEACHIN 24-JUN-99	 AMP Incorporated Harrisburg, PA 17105-3608			
DIMENSIONS: INCHES		CHK G.S. RIDGILL 19-JUL-99				
TOLERANCES UNLESS OTHERWISE SPECIFIED:		APVD G.S. RIDGILL 19-JUL-99	NAME			
0 PLC ±- 1 PLC ±- 2 PLC ±- 3 PLC ±.010 4 PLC ±- ANGLES ±-		PRODUCT SPEC	SOCKET, MSS, SERIES 4			
MATERIAL -		APPLICATION SPEC	SIZE	CAGE CODE	DRAWING NO	RESTRICTED TO
FINISH SEE TABLE		WEIGHT -	A3	00779	C- 645500	-
CUSTOMER DRAWING			SCALE NTS	SHEET 1 OF 1	REV D	